

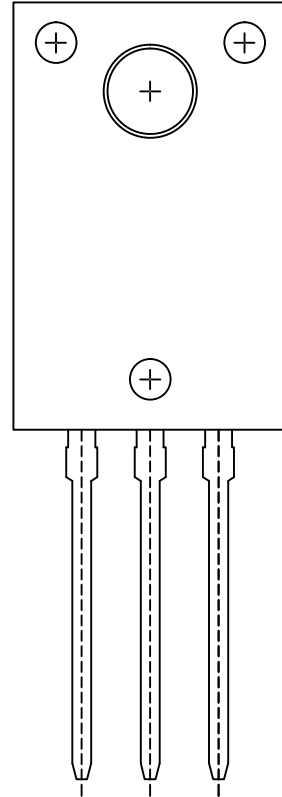

MARK	REVISION RECORD	VERSION	REVISERE
①	按模具尺寸调整部份尺寸;	B	
②	修改顶针直径及增加深度示意图;	C	

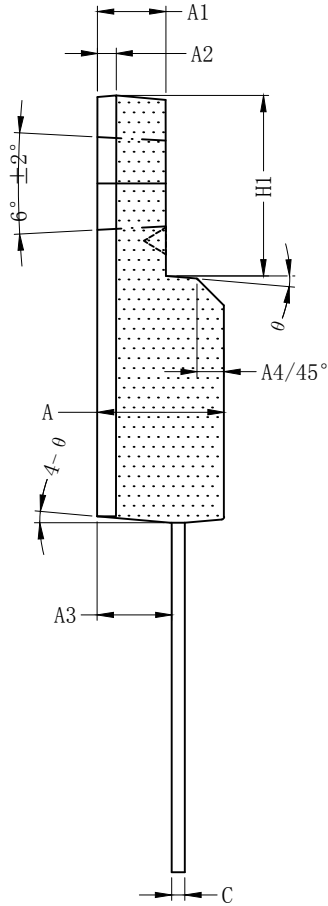

SYMBOL	MILLIMETER		
	MIN	NOM	MAX
A	4.50	4.70	4.83
A1	2.34	2.54	2.74
A2	0.70REF		
A3	2.56	2.76	2.93
A4	1.00BSC		
b	0.60	0.70	0.80
b1	1.05	1.15	1.25
C	0.45	0.50	0.60
D	15.67	15.87	16.07
D1	14.27	14.47	14.67
D2	10.88	11.08	11.28
E	9.96	10.16	10.36
e	2.54BSC		
H1	6.48	6.68	6.88
L	12.68	12.98	13.28
L1	--	--	2.00
L2	6.50REF		
φP	3.08	3.18	3.28
φP1	1.40	1.50	1.60
Q	3.20	--	3.40
θ	3°	5°	7°

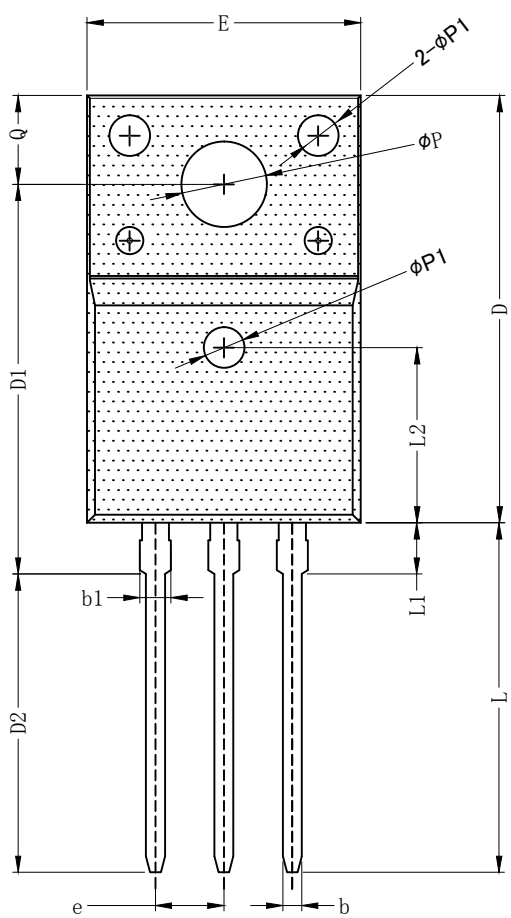
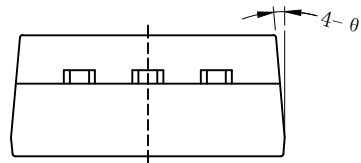

NOTES: 1. PKG SURFACE IS MATTE Ra1.2~1.4;
OTHERS IS POLISHED Ra0.15;

THIRD ANGLE PROJECTION		SCALE	UNIT	mm	TITLE	
		DATE	2023-09-19		T0-220FJ-3L产品成型图	
TOLERANCE		DESIGNER	CHECKER	APPROVER	DWG.NO.	MT-PD-153
		陈露			VERSION	C 第1页 共1页
		2023-09-19				