

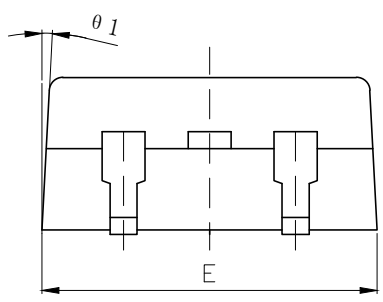

MARK	REVISION RECORD		REVISERE	APPROVER
①				
②				

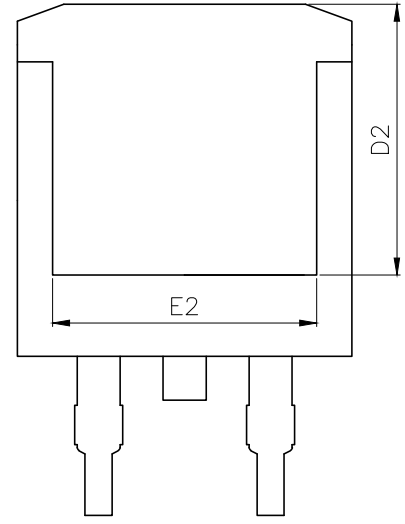
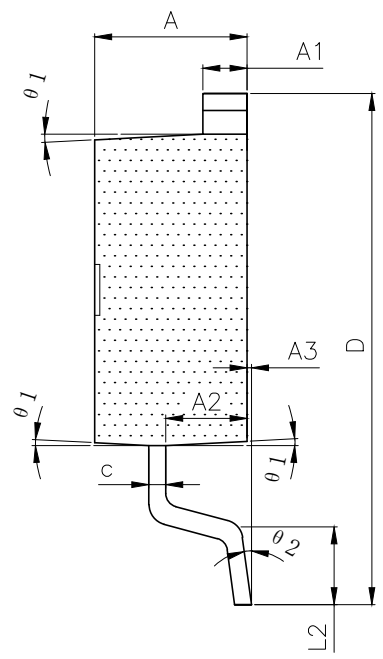
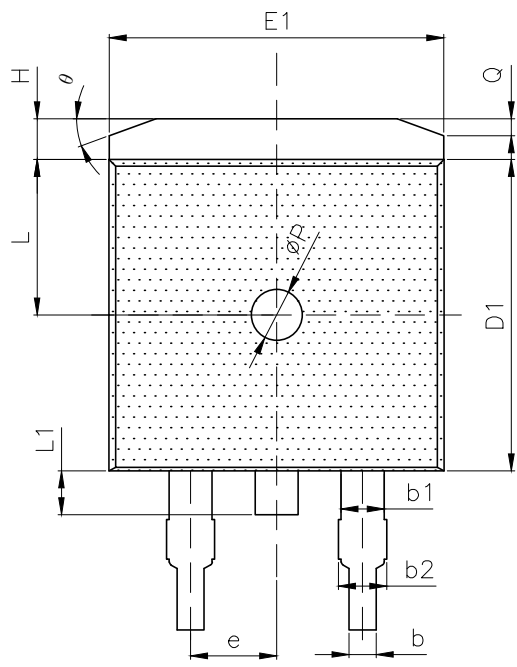

SYMBOL	MILLIMETER		
	MIN	NOM	MAX
A	4.40	4.50	4.60
A1	1.20	1.30	1.40
A2	2.30	2.40	2.50
A3	0.03	0.13	0.23
b	0.70	0.80	0.90
b1	1.21	1.27	1.40
b2	1.25	1.35	1.45
c	0.40	0.50	0.60
D	14.80	15.10	15.40
D1	9.10	9.20	9.30
D2	8.00	--	--
E	9.70	9.90	10.20
E1	9.68	9.88	10.08
E2	7.80	--	--
e	2.54 (BSC)		
H	1.00	1.20	1.40
L	4.30	4.60	4.90
L1	1.10	1.30	1.50
L2	2.10	2.30	2.50
phi P	1.40	1.50	1.60
Q	0.50 (REF)		
theta	16°	20°	24°
theta 1	1°	3°	5°
theta 2	0°	-	9°

NOTES: 1. PKG SURFACE IS MATTE Ra1.2~1.4;
OTHERS IS POLISHED Ra0.15;

 THIRD ANGLE PROJECTION	SCALE	UNIT	mm	TITLE	
	DATE	2022-04-21		T0-263-2L产品成型图(2)	
TOLERANCE		DESIGNER	CHECKER	APPROVER	
		陈露			
		2022-04-21			
		DWG.NO.	MT-PD-102		
		VERSION	A	第1页 共1页	